



RESPIREX™



Instructions for use of Frontair 2 Suit



EN1073-1:1998

Contents

General Information	1
Limitations & Warnings	2
Pre-Checks	3
Maximum and Minimum Airflow	4
Donning Procedure	5
Doffing Procedure.....	6
Tear-Off Doffing/Evacuation Strip (optional)	7
Inspection Of Component Parts	7
Instructions For Use Of Fall Arrest Harness	8
Use Of Optional Welding Face Screen	9
Fitting Face screen	9
Care & Maintenance of Visors/Face Screens	10
Storage.....	10
CHEMPROTEX™ 300 suit Type 3 and Type 4.....	11
Material Performance Data.....	11
Protection against infective agents.....	11
Product Labelling.....	12
Sizing	13
EU Declaration of Conformity.....	14

General Information

The Respirix Frontair 2 suit is designed for use within certain contaminated environments only. You must carefully read and follow these operating instructions closely.

The suit is designed as a single use garment and should not be re-used.

The suit must be supplied with breathable air from an external compressed air source providing positive pressure. The quality of breathing air flowing into the suit unit must comply with EN12021.

All Respiratory Protective Clothing is CE marked to indicate compliance with the European Regulation (EU) 2016/425 on personal protective equipment (PPE). The Frontair 2 suit complies with EN 1073-1:1998 (ventilated protective clothing against particulate radioactive contamination); this specifies the performance requirements for the suit and its materials of construction. Physical performance results for the main material of construction are detailed on page 11 of these User Instructions.

In addition the Frontair 2 suit in the Chemprotex™ 300 fabric, complies with the requirements of EN 14605: 2005 +A1: 2009 for protective clothing against liquid chemicals with liquid-tight (Type 3) or spray-tight (Type 4) connections.

Air flowing into the suit is divided into two streams, 50% flows to the hood for breathing purposes and 50% is fed to the arms and legs via a network of internal tubes to provide ventilation. The internal air system is permanently fitted and cannot be removed from the suit.

The suit provides a class 5 (50,000) nominal protection factor according to EN 1073-1:1998.

Limitations & Warnings

- The garment must only be used in the hazardous area for which it is intended. Always follow the instructions carefully otherwise the protection offered by the garment may be drastically affected.
- The user shall be the sole judge for the correct combination of full body protective coverall and ancillary equipment (gloves, boots, respiratory equipment etc) and how long the suit can be worn on a specific application with respect to its protective performance, wearer comfort or heat stress.
- Suit designed for single use only. Do NOT re-use
- At high work rates the pressure in the suit may become negative at peak inhalation flow or during bending or squatting.
- Adequate protection may not be provided by the suit in atmospheres that are immediately dangerous to life or health (IDLH).
- The suit must NOT be used with oxygen only or oxygen enriched air.
- The internal air system features a silencer which cannot be removed. If the silencer becomes blocked there will be a reduced air flow to the suit. To prevent the possibility of the silencer becoming blocked, breathing air must be adequately filtered at all times.
- Care must be taken to ensure that the suit is being used from the correct length and bore of air supply hose as a low airflow may cause a less efficient protection.
- In order to achieve the claimed protection of TYPE 3 (liquid-tight) and TYPE 4 (spray-tight) chemical protective clothing it is necessary to externally "tape-seal" the zipper flaps of suits manufactured from laminate materials using a suitable liquid impermeable tape.
- Wearers of Frontair 2 suits should be physically fit and capable of wearing the garments under the anticipated conditions of work. If in doubt please seek medical guidance before wearing.
- The suit is manufactured from non-breathable materials. Persons who show any signs of excessive stress such as fever, nausea, dizziness, eye irritation, difficulty in breathing, becoming fatigued or any unusual order or taste should leave the work area immediately and remove themselves from the suit.
- Materials used in the construction of Frontair 2 suits are not known to cause allergic reactions to the majority of individuals. Frontair 2 suits contain no components made from natural rubber latex.
- Stored in its normal packaging Frontair 2 suits have a maximum shelf-life of 10 years.
- Always use compatible PPE, e.g. gloves and safety boots advised by Respirex.

For any enquiries please contact the Respirex customer services department on

Tel : +44 (0)1737 778600, Fax : +44 (0)1737 779441 or Email : info@respirex.co.uk

Pre-Checks

Under the Control of Substances Hazardous to Health (COSHH) regulations 2002 and the European Regulation (EU) 2016/425, a thorough examination of respiratory protection equipment (RPE) is required to be undertaken in a clean area at least once per month if the garment has not been used. When in use Respirex recommend that the RPE is always checked before the start of each shift cycle. These inspections are required to ensure that the RPE will perform as intended and is free from defects.

Each inspection must be recorded and the following noted : date, serial number, name of examiner, condition of the equipment and details of any defect found. The inspection records will be kept by relevant Health & Safety departments for a period of at least five years.

1. Visually inspect the suit for any damage that may impair correct operation.
2. Ensure that the breathing air pack is securely attached and is not damaged.
3. The suit is free from contamination both internally and externally.
4. The suit is free from tears and holes; paying particular attention to the seam areas.
5. Vision through the visor is not obscured by large scratches or scuff marks.
6. Respirex recommend that the exhalation valves are part of the visual pre-check. If the valve diaphragm is distorted or damaged in any way it must be replaced.

Inspection of the compressed air supply tube (medium pressure connecting hose) which supplies breathing quality air to the operator must be carried out at least once per month and before each shift cycle and the results recorded.

During the inspection the following should be checked:

1. Lines are clean externally.
2. Lines are free from damage (holes, splits, etc).
3. Air line coupling connections are in good working order.

Submerge in water to locate any leaks if any sign of external damage is evident.

Report any defects to the supervisor and record them. The compressed air supply tube must NOT be used until the defect has been rectified.

Maximum and Minimum Airflow

The airflow to the suit must be within the range.

Maximum 600 litres/min (21.2 CFM).

Minimum 265 litres/min (9.4 CFM).

The suit is approved for use with the following combinations of hose length and pressure range to achieve the flow rates above:

Pressure range of 3.2 bar - 4.6 bar at supply (46 psi - 67 psi).

The suit must be connected with a minimum hose length of 10m and a maximum hose length of 60m. A maximum of one joint is permissible in any intermediate hose length between 10m and 60m, e.g 2 x 15m, 2 x 20m or 2 x 30m.

Notes:

- Bore size of hose must be 9.5mm.
- Hose lengths of 10m must have no joints.

If the end-user's pressure range falls outside that detailed above, or hose lengths/bore sizes are different to those specified, contact Respirex International Ltd for further information.

High/Low flow control valve

A control valve is fitted which can vary the airflow into the suit. By turning the valve between maximum (+) and minimum (-) the airflow will be vary by approximately one third. Note: the suit must be connected with the hose lengths specified to achieve this range.

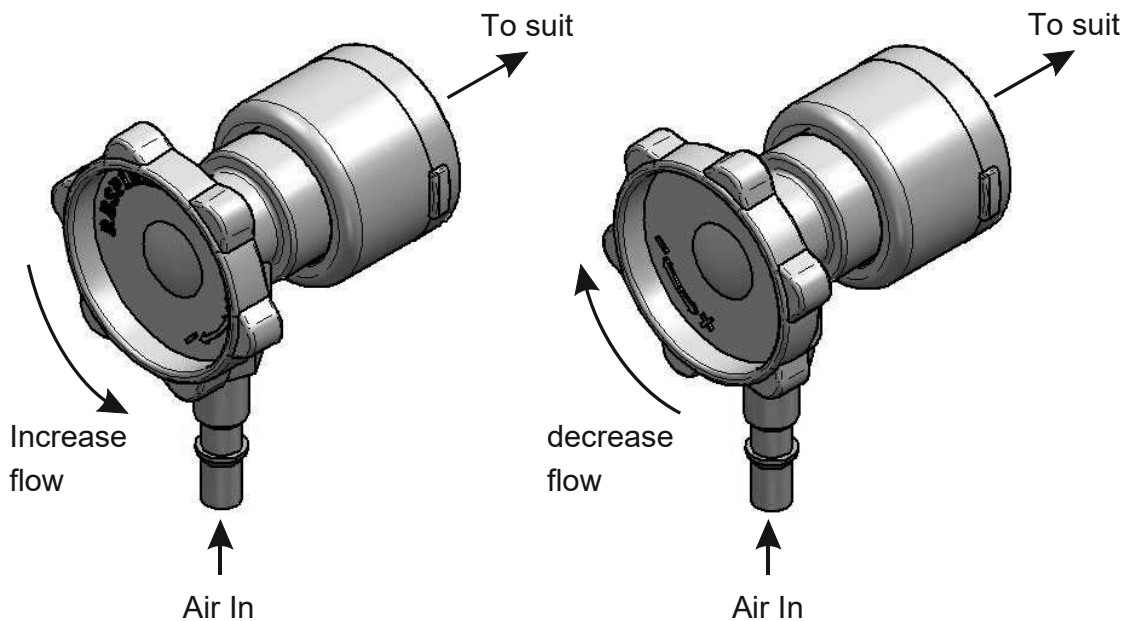

Donning Procedure

It is strongly recommended that before anybody attempts to wear or use a Frontair 2 suit, full training is given on wearing and decontamination by a competent person and the details of the training recorded. For safety purposes it is best to have an assistant to help you don and doff the suit. This makes the process easier and quicker and you will avoid stumbling or tripping which may result in personal injury or damage to the suit.

Note: The suit is designed to have footwear worn internally.

Follow these steps in putting on the suit:

1. With suits manufactured from PVC fully open the outer and inner zippers. These can be fitted either vertically or horizontally at the rear of the suit or horizontally across the chest. Fig. 1 shows a suit with a vertically fitted rear zipper arrangement. Suits manufactured from laminate material have a single zipper fitted either vertically or horizontally at the rear of the suit or horizontally across the chest.
2. With the aid of an assistant step into the lower half of the suit and slide your feet down the legs into the integral feet (Fig. 1). Fasten the ankle ties securely in a bow (Fig. 2).



Fig. 1



Fig. 2

3. Raise the suit to waist level, arrange the waist belt comfortably and fasten firmly.
4. Connect the suit to an air source supplying air compliant with EN12021 (Fig. 3). Ensure that the air supply hose is fed through the support attached to the suit.
5. With the help of the dressing assistant lift the suit up onto the shoulders and place your arms into the sleeves.



Fig. 3

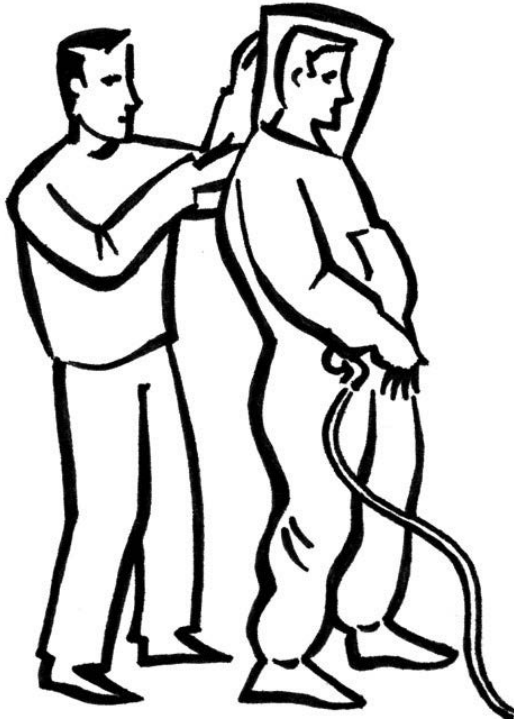

Fig. 4

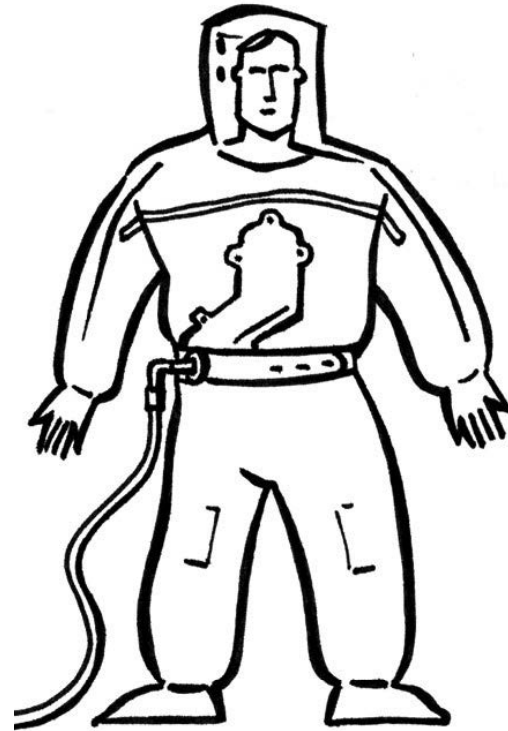

Fig. 5

6. Pull the hood of the suit over your head (air supply MUST be connected).
7. With PVC suits the dressing assistant should close the inner and outer zippers, (Fig. 4).

or

For suits manufactured from laminate materials, peel off the backing paper from the self-adhesive strips attached to the outer zip flap and seal down securely against the suit. The outer zip flap should then be taped externally using a suitable liquid impermeable tape. It is important that the outer flap is evenly sealed down to ensure that the suit inflates correctly and to provide the necessary degree of protection against inward leakage. Do not attempt to enter the working environment before sealing down the outer zip flap.

8. The suit will now inflate fully, (Fig. 5).

On completion of the donning procedure the wearer is now ready to enter the work environment.

Doffing Procedure

Note: The person assisting in the doffing procedure should be wearing appropriate PPE selected by qualified safety personnel.

1. The assistant should unfasten the outer and inner zipper (remove taping where applicable).
2. With the aid of the assistant pull the hood of the suit forwards over the head and remove arms from the sleeves
3. Lower the suit to the waist and disconnect from the compressed air supply.
4. Lower the suit to ground level, unfasten ankle ties and step out suit.
5. After use decontaminate or dispose according to your company procedures.

Tear-Off Doffing/Evacuation Strip (optional)

Suits manufactured from PVC and PU materials can be supplied with a 'tear-off' strip fitted horizontally across the chest. Under normal conditions this can be used as means of rapidly doffing the suit. Alternatively the strip can be used in emergencies to enable rapid doffing of the suit for evacuation purposes.

Simply grasp one end of the strip from an outstretched arm (Fig. 7) and tear across the chest. Remove arms from sleeves, withdraw head from hood, lower suit to ground level and unfasten ankle ties. Step out of the suit (Fig. 7).

Note: Once the evacuation strip has been utilised the suit is no longer operational.

This feature is not available on suits manufactured from laminate materials.



Fig. 6



Fig. 7

Inspection Of Component Parts

A regular inspection program should be conducted by employees.

The Frontair suit and all component parts and assemblies should be inspected for damage before each use to ensure proper functioning. Immediately remove the suit from service and replace parts or assemblies that show any sign of failure that might reduce the degree of protection originally provided.

Use only Respirex components and replacement parts.

Instructions For Use Of Fall Arrest Harness

Note: Option only available on suits manufactured from 300 micron PVC with horizontally fitted zippers.

WARNING : This facility must only be used in conjunction with a fall arrest harness approved to EN 361:2002 with a back 'D' ring fixing and a portable Respirex retractable airline hose reel. Always follow the manufacturer's recommendations for use, inspection and cleaning of safety belts and harnesses.

1. Don the fall arrest harness according to manufacturer's instructions ensuring that the back 'D' ring fixing point is between the wearer's shoulder blades. See Fig. 8.
2. Don the suit as outlined on page 5 as far as stage 5.
3. Pull the harness trunk on the suit inside out and down towards the 'D' ring fixing point of the fall arrest harness. Connect the 'D' ring on the fall arrest harness to the internal harness link using a connector approved to EN 362:2004. See Fig. 9.
4. Complete the donning procedure for the suit as described on page 6.
5. Attach the exterior harness link on the suit to an inertia block fall arrest device approved to EN 360:2002

NOTE: When an suit is being worn in conjunction with a fall arrest harness the trunk at the rear of the hood must concertina flat towards the wearer's neck. This is to ensure that in the event of a fall the movement of the harness is taken up by the trunk. This prevents damage occurring to the suit. See Fig. 10.

At no time must the operator work at greater than 1m horizontal distance from the attachment point on the inertia block fall arrest device.

At all times the operator must maintain a quantity of slack airline at their working location, thus avoiding any potential for the airline hose to become stress loaded in the event of a fall. At least 5m of coiled hose must remain wound onto the portable Respirex retractable hose reel, which will then be carried by the operator and attached to a point immediately adjacent to the working location.



Fig. 8



Fig. 9



Fig. 10

Use Of Optional Welding Face Screen

These instructions refer to Frontair 2 suits designed for use with face screens to protect against non-ionising radiation arising from welding and similar operations. To be used in accordance with current Eye Protection Regulations and must be worn when the process or job for which it is provided is being carried out. Ensure you understand when it should be worn and if there are any queries consult your supervisor.

The face screen must **ONLY** be fitted with the following combination of lenses:

4.25" (10.8cm) x 2" (5.1cm) Clear Cover Glass AND a

4.25" (10.8cm) x 2" (5.1cm) Green lens conforming to EN169:2002.

Note: The Clear cover glass is worn outermost from the eye.

Fitting Face screen

Don the suit as detailed in the user instructions with the following additional stage for use of the welding face screen.

Proceed to the work area. Before commencing work secure the outer glare shield fitted with flip-up welding lens holder to the visor using the velcro attachment points provided, see Fig. 11 (to achieve the best grip try to ensure that the attachment points on the glare shield line up with those on the visor).

Ensure that the filter lenses are at eye level.

Note: A heat resistant over-suit and hood is available which helps to prevent damage from welding splash, please contact Respirex for further information.

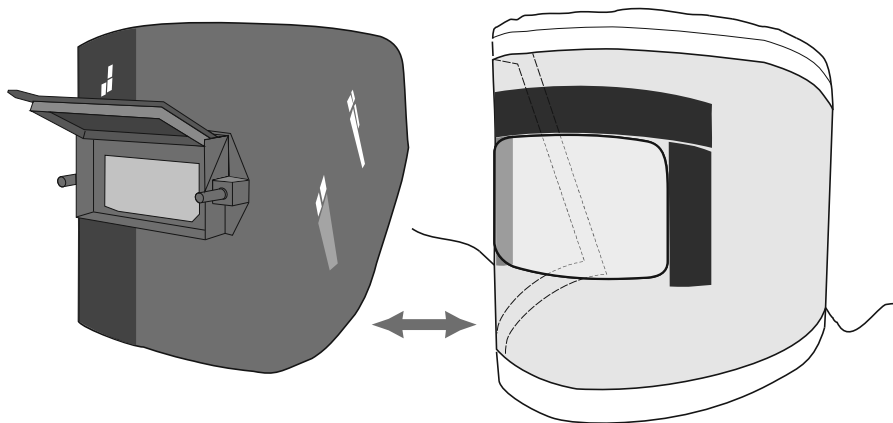

Fig. 11

Care & Maintenance of Visors/Face Screens

Can be cleaned using a mild solution of soap and warm water. Wipe with a soft cloth or tissue and allow to dry. Under no circumstances use an external heat source for drying. Periodic disinfecting with a dilute solution of a proprietary disinfectant will enhance wearer comfort. Pitted or scratched lenses reduce vision and seriously reduce protection - replace immediately.

Regardless of the above recommendations visors and face screens should be examined for damage such as scratches, abrasions, cracks etc. before use, and should also be examined for deterioration. Damaged face screens and visors should be replaced. Lenses subjected to chemical splashes or significant impact should also be replaced.

Warning

Materials that may come into contact with the wearer's skin are not known to release substances that are toxic, carcinogenic, mutagenic, allergenic, toxic to reproduction or otherwise harmful to the majority of individuals. These products contain no components made from natural rubber latex.

Storage

If the suit is to be stored in a box or container it should be folded so that the breathing air pack and visor is not distorted. Always store the suit in a dry condition.

In order to maintain the level of protection offered, care should be taken to minimize the risk of damage occurring to the Frontair 2 suits during transportation between work areas. It is recommended that all Frontair 2 suits are transported in a suitably sized rigid container resistant to penetration by sharp objects, abrasive surfaces, chemicals, oils, solvents etc.

CHEMPROTEX™ 300 suit Type 3 and Type 4

Tests carried out under laboratory conditions by independent accredited laboratories.

Performance requirement	Test method	Property value	Result
EN14605:2005+A1:2009 clause 4.3.4.3	EN ISO 17491-3:2008	Resistance to penetration by a jet of liquid (jet test)	Pass
EN14605:2005+A1:2009 clause 4.3.4.2	EN ISO 17491-4:2008	Resistance to penetration by a spray of liquid (spray test)	Pass

Material Performance Data

Tests carried out under laboratory conditions by independent accredited laboratories in accordance with the requirements of EN 14325:2004.

Minimum CLASS as per EN 14325:2004		Class		
		150 micron PVC	300 micron PVC	Chemprotex™ 300
Abrasion resistance	EN 530:2010 method 2	6/6	6/6	6/6
Flex cracking resistance	EN ISO7854:1997 method B	4/6	6/6	1/6
Trapezoidal tear resistance	EN ISO 9073-4:1997	1/6	2/6	4/6
Tensile strength	EN ISO13934-1:2013	3/6	4/6	3/6
Puncture resistance	EN 863:1996	1/6	2/6	2/6
Seam strength	EN ISO13935-2:2014	4/6	4/6	*4/6
Kemblok™ to suit seam strength	EN ISO13935-2:2014	N/A	N/A	4/6
Sodium Hydroxide 40% Permeation	EN ISO 6529: 2001	N/A	N/A	6/6
Sodium Hydroxide 40% Seam Permeation	EN ISO 6529: 2001	N/A	N/A	6/6
Sodium Hydroxide 40% Kemblok™ to suit seam permeation	EN ISO 6529: 2001	N/A	N/A	6/6

*Fabric tear at the jaws

Protection against infective agents

Tests carried out under laboratory conditions by independent accredited laboratories in accordance with the requirements of EN 14126:2003.

Minimum CLASS as per EN 14126:2003		Class
		Chemprotex™ 300
Synthetic blood penetration resistance	ISO 16603:2004	✓
Blood-borne pathogen penetration resistance	ISO 16604:2004	6/6
Contaminated solid particle penetration resistance	EN ISO 22612:2005	3/3
Contaminated liquid aerosol penetration resistance	ISO/DIS 22611:2003	3/3
Wet bacteria penetration resistance	EN ISO 22610:2006	6/6

Product Labelling

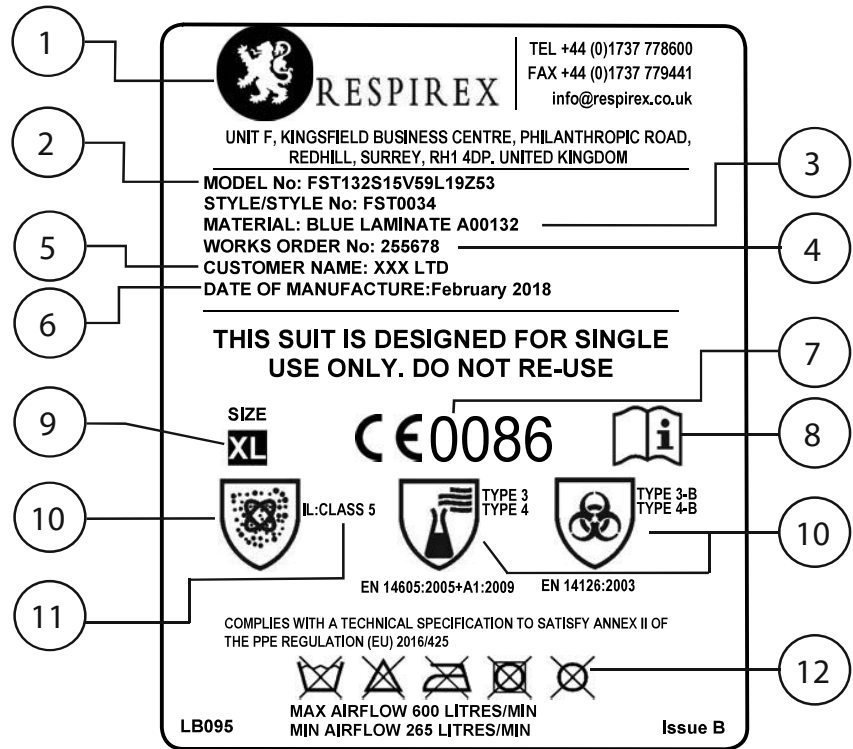

1. Manufacturer of garment;
2. Manufacturer's Model No.
3. Material of Manufacture.
4. Manufacturer's Order No.
5. Customer Name.
6. Date of manufacture; Day/Month/Year.
7. CE Mark and notified Body code.
8. "Open Book Pictogram"; wearer must refer to the "Instructions for use" for further information.
9. Garment Size.

Size	Chest (cms)	Height (m)
S	88-96	1.64-1.70
M	96-104	1.70-1.76
L	104-112	1.76-1.82
XL	112-124	1.82-1.88
XXL	124-136	1.88-1.94

10. Pictograms defining protection types: Protection against particulate radiation; Protection against liquid chemicals and infective agents (only for models made from A00132 material)
11. Inward leakage class.
12. Five care pictograms indicating whether clothing is suitable for cleaning and reuse.
 - Pictogram 1 Light Mechanical Washing or Do not wash (shown)
 - Pictogram 2 Do not bleach
 - Pictogram 3 Do not iron
 - Pictogram 4 Do not machine dry
 - Pictogram 5 Do not dry clean

Sizing

The following pictograms designate the range of height & chest sizes suitable for specific sizes of Frontair 2 suit, check your body measurements and select the correct size of suit. Body measurements in cm.

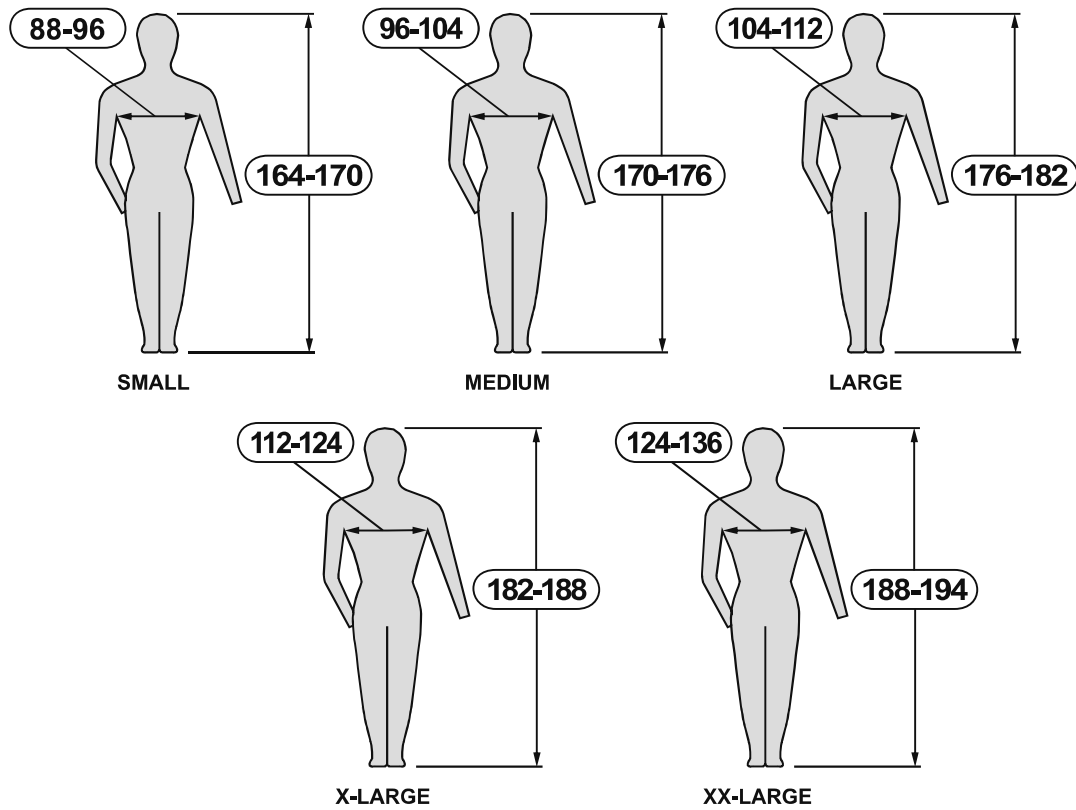

Size	Height	Chest
S	164-170	88-96
M	170-176	96-104
L	176-182	104-112
XL	182-188	112-124
XXL	188-194	124-136



EU DECLARATION OF CONFORMITY

RESPIREX INTERNATIONAL LTD
Unit F Kingsfield Business Centre,
Philanthropic Road,
Redhill,
Surrey RH1 4DP
United Kingdom

Declares that the PPE described hereafter:

**Respirex Frontair 2 Suits:
Manufactured using 165g/m² barrier laminate on non-woven fabric (Part no. A00132)**

Meets the minimum requirements specified by product standards:

EN 1073-1: 1998	<i>Protective clothing against radioactive contamination - Requirements and test methods for ventilated protective clothing against particulate radioactive contamination.</i>
EN 14605: 2005 +A1: 2009	<i>Protective clothing against liquid chemicals – Performance Requirements for clothing with liquid-tight (type 3) or spray-tight (type 4) connections, including items providing protection to parts of the body only (Types PB[3] and PB [4])</i>
EN 14126: 2003	<i>Type 3-B, Type 4-B & Type 5-B (Full body protective clothing against infective agents)</i>

is in conformity with the provisions of Annex II of the PPE Regulation (EU) 2016/425 and is identical to the PPE which is subject of Module B EU type-examination certificate CE 709514 and subject to the procedure set out in Module D of the European PPE Regulation (EU) 2016/425, which both certificates are issued under the supervision of the approved body:

BSI,
Davy Avenue, Knowhill,
Milton Keynes, MK5 8PP,
United Kingdom
EU Notified Body No 0086

These garments are described in the manufacturer's technical file TF069, Issue C.

Done at: RESPIREX, Redhill, Surrey, on 22nd February 2018

Signed:.....

Mark Bellas Simpson (Managing Director)



Registered in England No. 592506 VAT No. GB 115 0754 43
Directors: M. Bellas Simpson A.C.A. D.G. Mackie PJ Wilson

Respirex International Limited
Unit F, Kingsfield Business Centre,
Philanthropic Road, Redhill,
Surrey RH1 4DP.
Tel: +44 (0) 1737 778600
Fax: +44 (0) 1737 779441
Email: info@respirex.co.uk
Web: www.respirex.co.uk



RESPIREX™

EU DECLARATION OF CONFORMITY

RESPIREX INTERNATIONAL LTD
Unit F Kingsfield Business Centre,
Philanthropic Road,
Redhill,
Surrey RH1 4DP
United Kingdom

Declares that the PPE described hereafter:

Respirex Frontair 2 Suits:
Manufactured using: 300 MICRON CALENDERED PVC FOIL (Part no. A00015)
150 MICRON CALENDERED PVC FOIL (Part no. A00131)

Meets the minimum requirements of product Technical Standard:

EN 1073-1: 1998

Protective clothing against radioactive contamination - Requirements and test methods for ventilated protective clothing against particulate radioactive contamination.

is in conformity with the provisions of Annex II of the PPE Regulation (EU) 2016/425 and is identical to the PPE which is subject of Module B EU type-examination certificate CE 709514 and subject to the procedure set out in Module D of the European PPE Regulation (EU) 2016/425, which both certificates are issued under the supervision of the approved body:

BSI,
Davy Avenue, Knowhill,
Milton Keynes, MK5 8PP,
United Kingdom
EU Notified Body No 0086

These garments are described in the manufacturer's technical file TF069, Issue C.

Done at: RESPIREX, Redhill, Surrey, on 22nd February 2018

Signed:.....

Mark Bellas Simpson (Managing Director)



Registered in England No. 592506 VAT No. GB 115 0754 43
Directors: M. Bellas Simpson A.C.A. D.G. Mackie PJ Wilson

Respirex International Limited
Unit F, Kingsfield Business Centre,
Philanthropic Road, Redhill,
Surrey RH1 4DP.
Tel: +44 (0) 1737 778600
Fax: +44 (0) 1737 779441
Email: info@respirex.co.uk
Web: www.respirex.co.uk

RESPIREX INTERNATIONAL LTD,

Unit F Kingsfield Business Centre,
Philanthropic Road,
Redhill,
Surrey RH1 4DP
United Kingdom

Tel. +44 (0) 1737 778600

Fax.+44(0) 1737 779441

www.respirexinternational.com

Type Examination By: **BSI,**

(Module B and Kitemark Court,
Module D) Davy Avenue, Knowhill,
Milton Keynes MK5 8PP
United Kingdom

Notified Body No. 0086